

miscēa LIGHT

FAST. CLEAN. SIMPLE.



misceda LIGHT

FAST. CLEAN. SIMPLE.

Did you know that **78%** of public bathroom users **prefer** to use **touchless soap dispensers and faucets** instead of manual systems!





Fast. Clean. Simple.

The **miscea LIGHT** range of sensor activated faucets have an integrated liquid dispenser system engineered directly into the faucet for convenience and hygiene benefits. Through fast and reliable sensor activation, the **miscea LIGHT** readily dispenses what you need and water for an efficient and convenient hand washing experience.

The **miscea LIGHT** system is not just an award winning system, but also a viable and effective solution for facilities . Yet it is elegant in design and simple enough to be used in any business or home.



product
design award

2014



German
Design Award

NOMINEE 2014

PRODUCT INFORMATION

FEATURES & TECHNICAL SPECIFICATIONS



Safer. Cleaner. More Hygienic.

The clever 2 in 1 design eliminates the need for frequent cleaning as any soap or disinfectant dripping from the user's hands are neatly contained in the sink resulting in no messy puddles for safer, cleaner and more hygienic facilities.

Intuitive User Interface

Using the **miscea LIGHT** is a completely touch free experience. It's as simple as moving your hand over the indicated section of the display to activate the product you want. The coloured LED light signals will show which product has been activated. To receive the product you have activated, simply place your hand under the faucet.

No separate dispensers

A dispenser has been engineered directly into the **miscea LIGHT** eliminating the need for separate dispensers. The **miscea LIGHT** is able to dispense a wide range of hygiene products from viscous liquids to gels and creams.

Safety Feature Against Bacteria

The **miscea LIGHT** system has an inbuilt safety feature against bacteria. It will automatically run a cleaning cycle, flushing water and both liquid dispensers to prevent harmful water-borne bacteria growth usually found in stagnant water. These cleaning cycles can be programmed to the desired frequency with the handy miscea remote control.

Be Smart. Save Water.

miscea Sensor faucet can lower water usage by up to 60%*. It works by ensuring water flows only when you really need it and automatically shuts off when you don't. Special aerators integrated into miscea faucets also help to reduce water consumption by enriching the water with air, resulting in a luxurious stream of bubbly water that is soft to the touch, non-splashing while using less water.

*Compared to manually operated faucets without water saving aerator: 3.5 gpm

Performance Specifications

Voltage	12 V _{DC}
Input Voltage	100 ~ 240 V _{AC} / 50 ~ 60 Hz
Operating water pressure	0,8 - 10 bar
Water flow rate (at 3 bar)	ca. 6 L/min
Max. water temperature	75 °C
Enclosure rating of PCB	IP 55
Faucet weight (incl. hoses & cables)	
Standard model:	1,0 kg
Wand model:	1,0 kg
Soap box (excl. pouches)	0,95 kg

Default Settings

Response time of water flow stop	1 sec
Dispense volume of soap ¹	1 ml
Dispense volume of disinfectant ²	3 ml

¹Only available with miscea LIGHT with integrated Soap dispenser
²Only available with miscea LIGHT with integrated Disinfectant dispenser

Finish Options



Polished Chrome

Faucet Interface Options



miscea LIGHT for water only



miscea LIGHT with Soap Dispenser



miscea LIGHT with Disinfectant Dispenser

Faucet Models & Dimensions

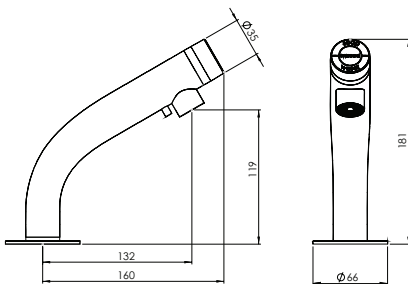

miscea LIGHT Standard

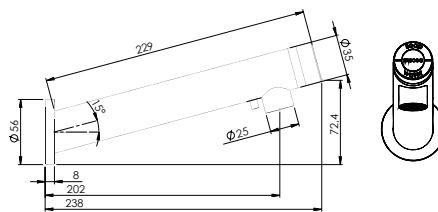

miscea LIGHT Wall

Soapbox Dimensions

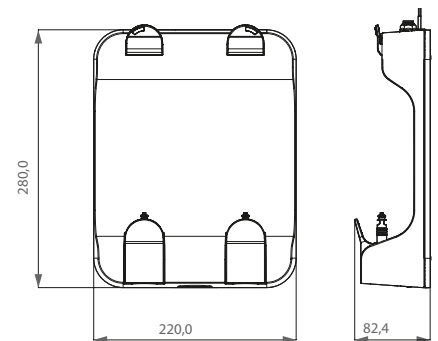

*miscea S1 Soapbox Pouch**

*Not available with miscea LIGHT water only model

REFILL PRODUCTS

HIGH QUALITY HAND HYGIENE PRODUCTS.



miscea Systems feature our unique and patented refill unit - It's a hygienic and efficient system for changing liquid products when your miscea runs out.

miscea S1 Soapbox for Pouch Refills

The **S1 Soapbox** for use with Soft Pouch Refills, is sleek and modern in design. It was engineered for use with vacuum sealed 1L pouches filled with high quality miscea liquid products.

This vacuum seal method maintains a high and stable quality of the contents inside, and ensures consistent dispensing of liquid hand hygiene products is consistently pumped through your miscea system.

Capable of holding a maximum total of 2 L of liquid products, the S1 Soapbox unit ensures the Soft Pouches are kept in a secure and upright position while connected to your miscea system ready to be used.





Hand Lotion



Disinfectant



Surface Disinfectant



Hand Wash



Detergent



Sensitive Hand Wash

Easy to install

When the product pouches are empty, it's as simple as opening the quick release handles to remove the empty pouch, placing the new pouch over the connector and closing the quick release handles. Fast, clean and simple!

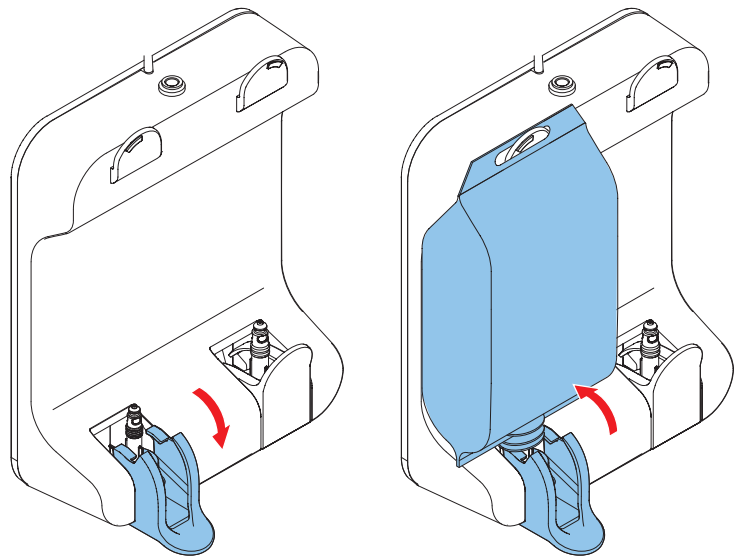

High Quality Liquid Products

miscea systems use high quality and effective skincare products. User's have a choice between a wide range of products compatible for use with miscea systems, from soaps and disinfectants to hand lotions and surface disinfectants.

Please visit our website for the full list of skincare products available.
www.miscea.com



miscea GmbH

Hauptstraße 2
14979 Großbeeren
Germany

T: +49 (0) 33701 3553 - 0
F: +49 (0) 33701 3553 - 19
E: berlin@miscea.com

miscea Benelux B.V.

Transportweg 9F
2421 LT NIEUWKOOP
The Netherlands

T: +31 (0) 172 76 91 39
F: +31 (0) 172 76 91 38
E: info@miscea.com



Schulthess Klinik, Orthopädie, Switzerland



Dental Clinic, The Netherlands



Hoffmann La Roche, Switzerland



All Dent, The Netherlands

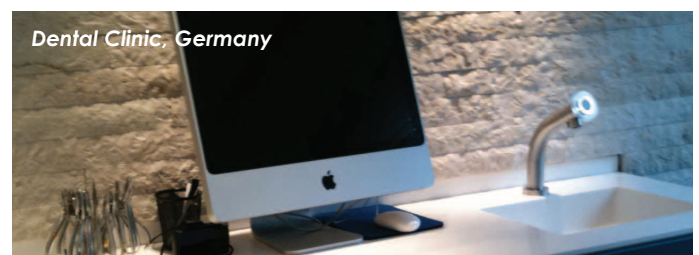

Dental Clinic, Germany

 www.facebook.com/miscea

 @misceabv

 www.youtube.com/themiscea

 www.miscea.com